

Stage 1 H/DUTY BALL RACE THRUST BEARINGS & Elastomer Centers **(STREET)**

STREET CAMBER & CASTER Adjustment For The 1st. Time

Also MANF. **STAGE 2** (STREET/RACE) and **STAGE 3** (FULL RACE) KITS Plus front (Track days) extra Camber & Caster performance bushings (Lower control arm and thrust arms inner also improving brake & steering response) For the Rear - Camber & Toe adjuster kit. (#193326)

✓ Can fit (and) adjust with strut brace fitted

Kits designed to simply replace original strut 'upper' mounts, no mods (All items above Coil spring except for OEM dust cover)

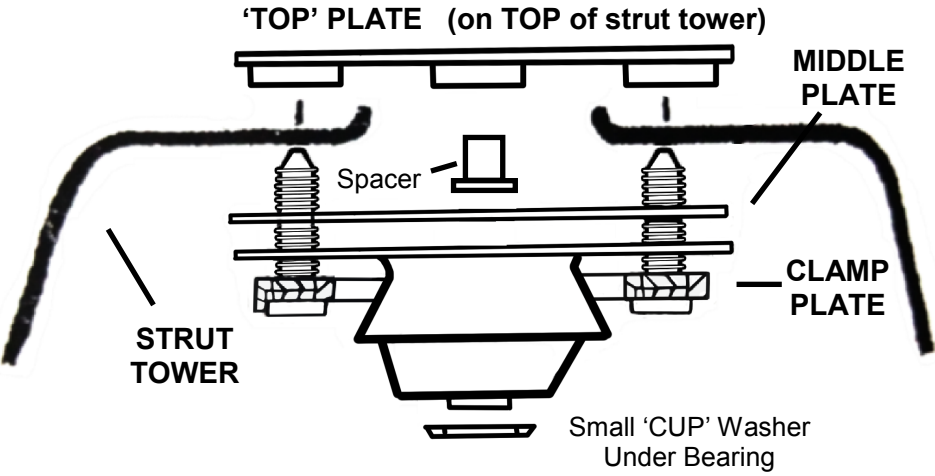

Refer manufacturers workshop manual re removal and installation
Observe all safety procedures

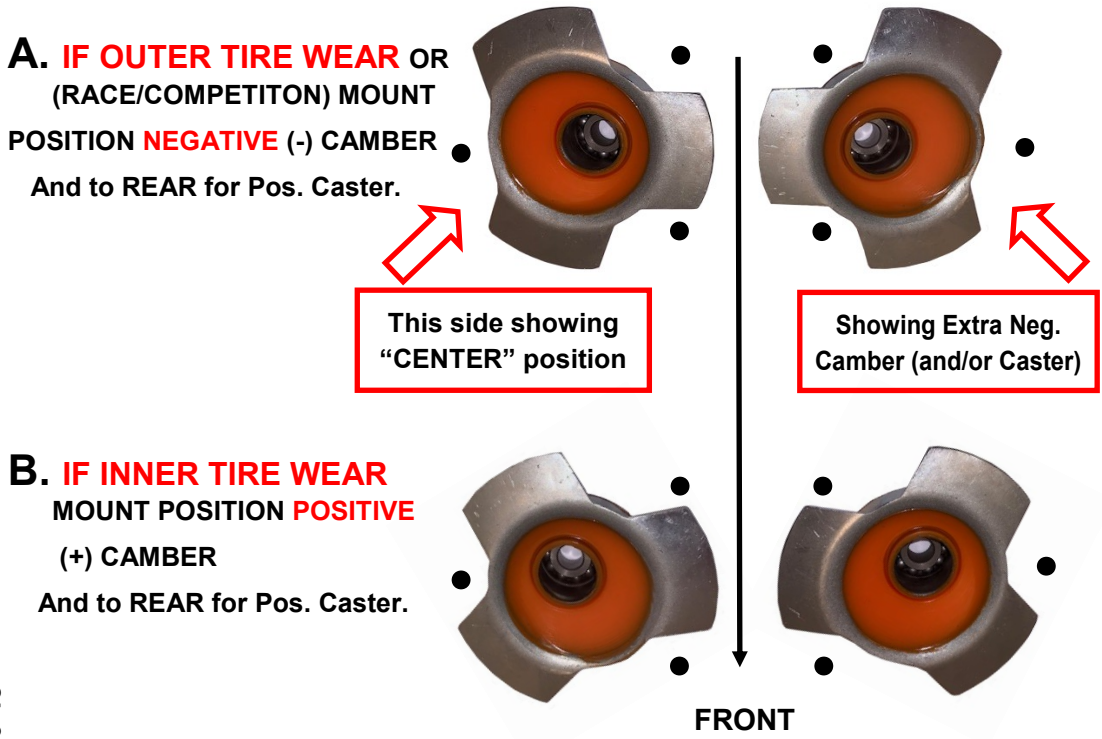

© KMAC Align 2022 #193416-1J

ALIGNING KMAC Patented design allows adjustment to be carried out accurately (under load). No need to jack vehicle.

- A. From engine bay, loosen the '3' top nuts for strut tower upper mount.
- B. Use large screwdriver to lever / ratchet KMAC adjuster mount crossways for CAMBER, then lengthways for required CASTER.
- C. Once optimum settings, tighten the 'TOP' KMAC NUTS to **27Nm (20ft/lbs)**.



FRONT #193416-1J STAGE 1 (STREET)

BMW E34 '5', E32 '7'

FRONT CAMBER (and CASTER) FOR THE 1st TIME
(and accurate-underload direct on alignment rack)

- ✓ **Quickest Adjustment** - Change Camber & Caster settings - from engine bay and with strut brace fitted
- ✓ **Centers H/Duty** - Ball Race (Thrust Bearings for steering loads with elastomer for extended wear life)

ALSO MANUFACTURED
STAGE 2 (STREET / RACE), STAGE 3 (FULL RACE).
SEE WEB SITE

- **FRONT** - Also extra Camber and Caster (Track days) - Lower arm inner bushes (Camber) and thrust arm for Caster. Both single wrench precisely adjustable.

Always 1st With The Latest Design Breakthroughs

- 1. WISHBONE:** Precise Ball Joint Adjustment System.
- 2. STRUT(top):** Biggest/Quickest Adjustment System.
- 3. BUSHINGS:** Single Wrench - Precise On Car Adjustment.
Including unique KMAC "non-slip" lock system!

Actual Inventors/Patentee's - The '3' Basic Suspension Systems

We do appreciate any ideas to further improve our market leadership !